

# HTPA120x84dL10/0.7UHIS

Thermopile Array with Lens Optics

Rev 7: 2023-11-14 Lupp / Nægler

Page 1 of 34



## Content

1	Changelog .....	2
2	Cleaning and Handling of Sensors with Optical Elements .....	3
3	Principal Schematic for HTPA120x84d .....	5
4	Pin Assignment – Bottom View .....	6
5	Optical Orientation.....	7
6	Order Code Example.....	8
7	Application note.....	9
8	Serial Order of Frame .....	10
9	Characteristics.....	12
9.1	Common Specifications.....	12
9.2	Optical characteristics.....	12
10	Electric Specifications.....	13
11	SPI Timings HTPA120x84d .....	15
12	SPI Communication .....	16
12.1	Write Command.....	16
12.2	Read Command.....	16
12.3	Sensor Commands .....	17
12.4	EEPROM communication .....	20
12.5	SPI Example Sequences – Init and Read Thermopile Array .....	21
13	Temperature calculation .....	22
13.1	Ambient Temperature .....	24
13.2	Thermal Offset .....	24
13.3	Electrical Offset .....	25
13.4	Vdd Compensation.....	25
13.5	Object Temperature .....	27
14	Example calculation .....	28
14.1	Pixel Masking .....	30
14.2	Look-up Table.....	33
15	Outer Dimensions.....	34

# HTPA120x84dL10/0.7UHiS

Thermopile Array with Lens Optics

Rev 7: 2023-11-14 Lupp / Nägler

Page 2 of 34



## 1 Changelog

2021-01-30	Revised order code; Added change notes; revised TRIM registers
2021-08-12	New order code; Added formula for pixel masking; Correction pixel size
2021-08-16	Added datasheet for L3.9/L4.8
2021-09-20	Corrected EEPROM map
2021-10-29	Deleted PU (not necessary), updated EEPROM-map, corrected absorbersize, delete address (sensor commands)
2022-01-26	Updated EEPROM Map
2022-04-21	Small corrections in exemplary calculations, corrected graph for SPI Timings
2022-08-01	Added L21.5 and L33 variant
2023-11-14	Note on the use of the SPI pin added

## 2 Cleaning and Handling of Sensors with Optical Elements

### Cleaning of Filter with Isopropyl Alcohol or Acetone

This is the method most universally used for cleaning optical elements with or without coatings. Filters or lenses mounted in our sensors may be cleaned rubbing the surfaces lightly with a clean, soft, all-cotton cloth or cotton swab during immersion in solvent or simply moistened with the solvent. The parts are then immediately wiped dry with another clean, soft, all-cotton cloth or cotton swab.

### Cleaning with Detergent and Water

A very mild, non-abrasive detergent (one which does not contain additives) and water may also be used for cleaning optical elements. In general, a detergent and water mixture is an excellent method for removing fingerprints and other smudges. The liquid detergent is first mixed with deionized water (proportions recommended by the manufacturer should be followed). The element is then washed, rinsed, and immediately wiped dry. Use a clean, soft cloth when cleaning and drying. If the part is allowed to dry in air, a permanent stain may result.

Please note:

- Do not use isopropyl alcohol or acetone or detergent if the elements will be mounted in an assembly with a finish which may be soluble by these solvents.
- Please avoid glass isolation being moistened by solvent.
- If the part is allowed to dry in air, a permanent stain may result.

### Handling Advises

Sensors with optical elements deserve special consideration in their handling and care. Ordinarily, filters or lenses are cleaned and inspected prior to shipment. If proper care is exercised during handling cleaning should not be necessary prior to use.

- Wear gloves when handling a sensor or optical element. Lightweight nylon or cotton gloves which are relatively lint-free are recommended.
- Avoid touching the surface of filters and lenses.
- Protect devices from static discharge and static fields.
- Thermopile sensors are electrostatic sensitive devices. Sensors should be handled over an electrostatic protected work area.
- Precautions should be taken to avoid reverse polarity of power supply for sensors with integrated signal processing. Reversed polarity of power supply results in a destroyed unit.
- Sensors should rest preferably in a partitioned container where the mounted filters or lenses will be not coming into contact with other material.
- During storage optical surfaces should be covered to avoid contamination from the surrounding environment.
- A covered container can eliminate damage during transportation and storage.

- Sensors or optical elements should be stored in a restricted access area to eliminate handling
- Do not expose the sensors to aggressive detergents such as freon, trichlorethylen, etc.
- Avoid rotating the sensors when they are soldered into a PCB or something similar
- Shortening of the pins is not suggested. This may cause cracks in the glass of the pins and result in a leakage.
- If this is necessary, a tool for this is recommended. Please contact Heimann Sensor for further information.

## Soldering Recommendations

**Attention:** For all of our array sensors we give no guarantee on the calibration and its performance if the pins are shortened by the customer. **Additionally, we strongly recommend to not solder the sensor with its back plate directly to a PCB.** This will cause different thermal conductivity compared to air and the measurement results could get worse. **Use a minimum gap between PCB and backplate of 2 mm or more.** The glass of the pins to the back plate can get damage by applying high temperatures (during soldering), which will lead into a lower temperature reading what cannot be repaired afterwards.

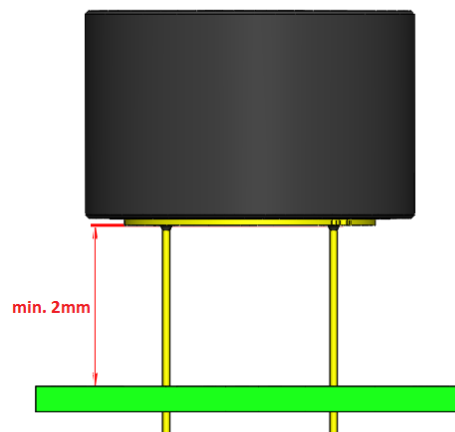

Figure 1: Soldering height

## Manual Iron Soldering and Automatic Point-to-Point Iron Soldering

Manual Iron Soldering and Automatic Point-to-Point Iron Soldering methods are allowed for TO packages. It is recommended for through hole applications to shield the package body from soldering heat by PCB or similar.

The soldering iron temperature should be set as low as possible (maximum 350 °C) and should not exceed recommended soldering time (maximum 3 seconds). The minimum distance between the housing body and the liquid solder should be at least 1.5 mm for 350 °C. Reflow soldering is not recommended.

## 3 Principal Schematic for HTPA120x84d

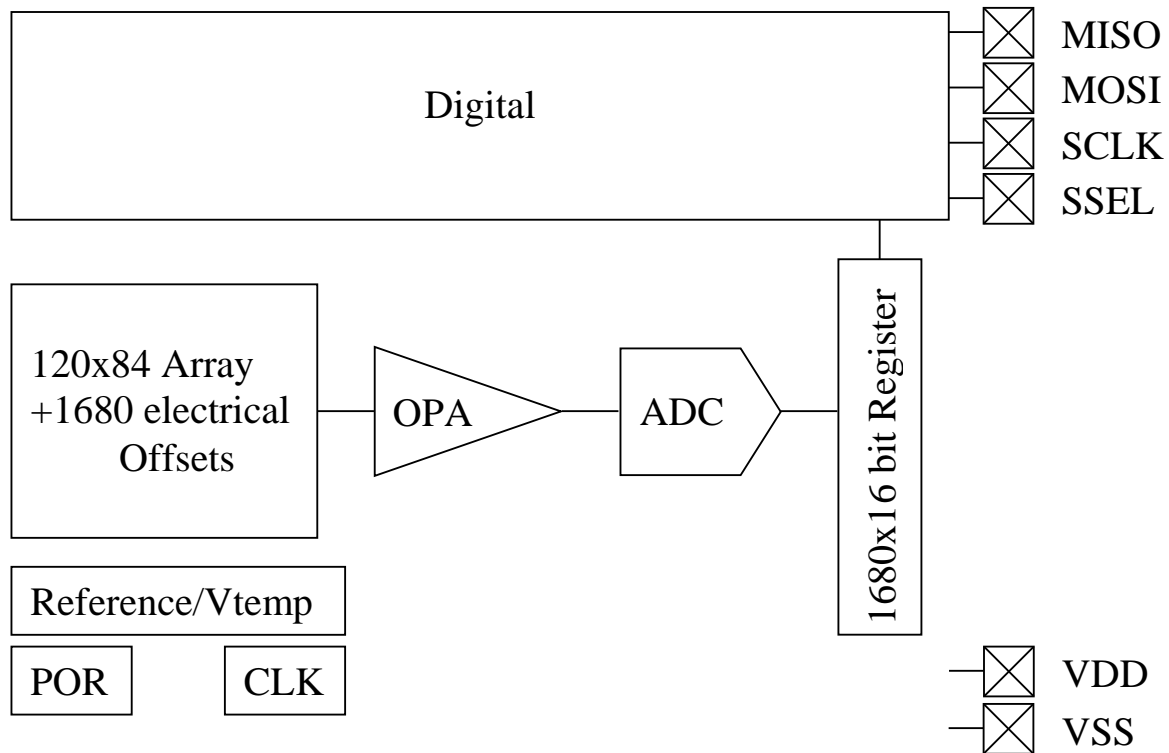

Figure 2: Schematic for HTPA120x84d

\* EE\_Enable : The slave select is used to switch communication between sensor and EEPROM.

# HTPA120x84dL10/0.7UHiS

Thermopile Array with Lens Optics

Rev 7: 2023-11-14 Lupp / Nägler

Page 6 of 34

## 4 Pin Assignment – Bottom View

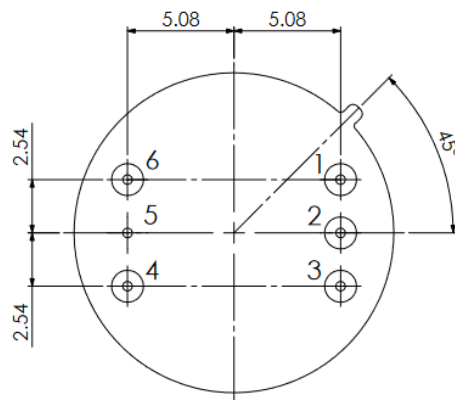

Figure 3: pin-allocation

Pin	Symbol	Description
1	MISO	Digital I/O, Serial data out of sensor
2	MOSI	Digital I/O, Serial data in of sensor
3	SCLK	Digital I/O, Serial clock
4	VDD	Positive supply voltage
5	VSS	Negative supply voltage / Ground (0V) (connected to housing)
6	$\overline{\text{EE\_Enable}}$	Digital I/O, Sensor/EEPROM select

# HTPA120x84dL10/0.7UHiS

Thermopile Array with Lens Optics

Rev 7: 2023-11-14 Lupp / Nägler

Page 7 of 34

## 5 Optical Orientation

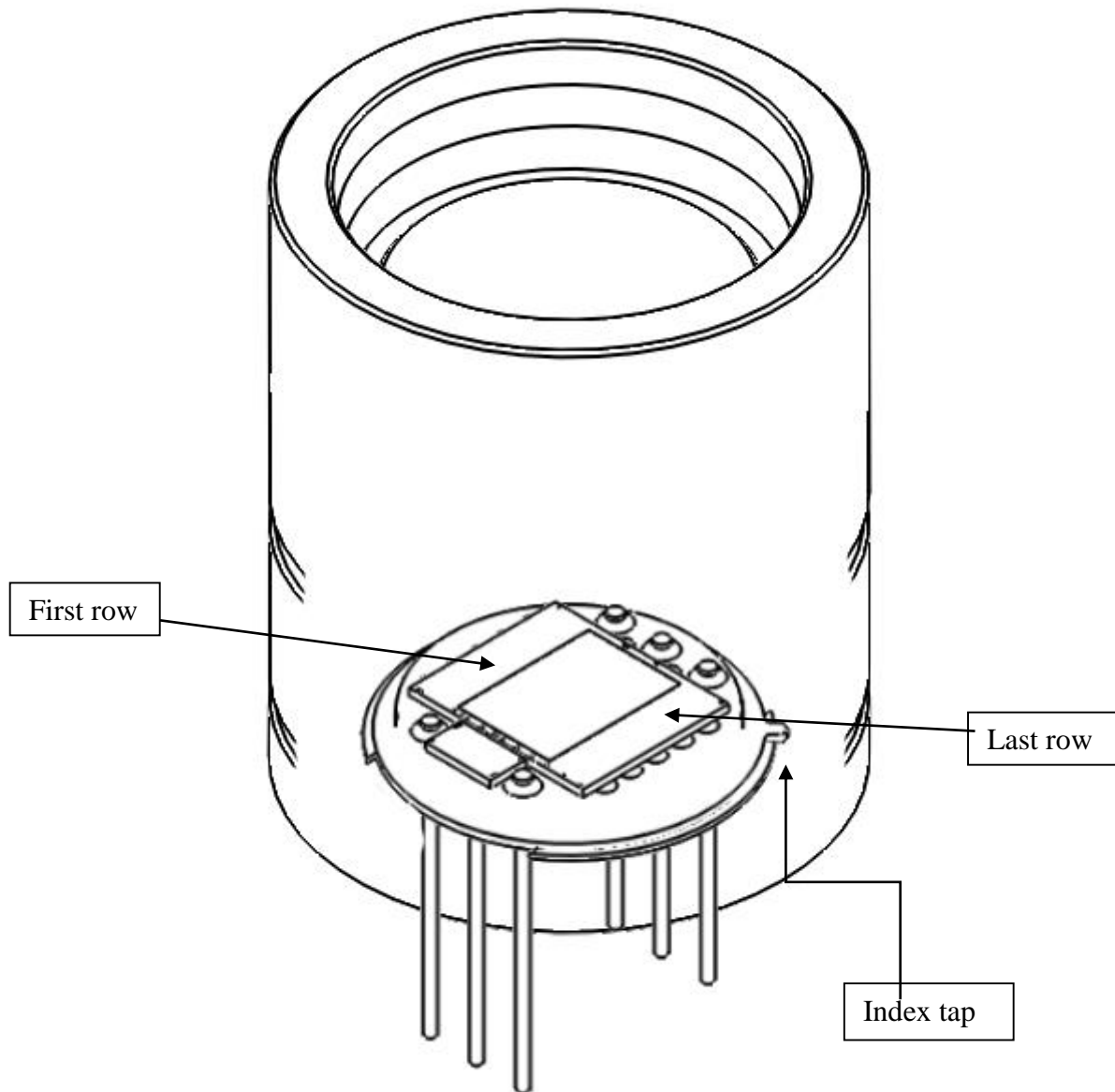

Figure 4: Optical orientation

## 6 Order Code Example

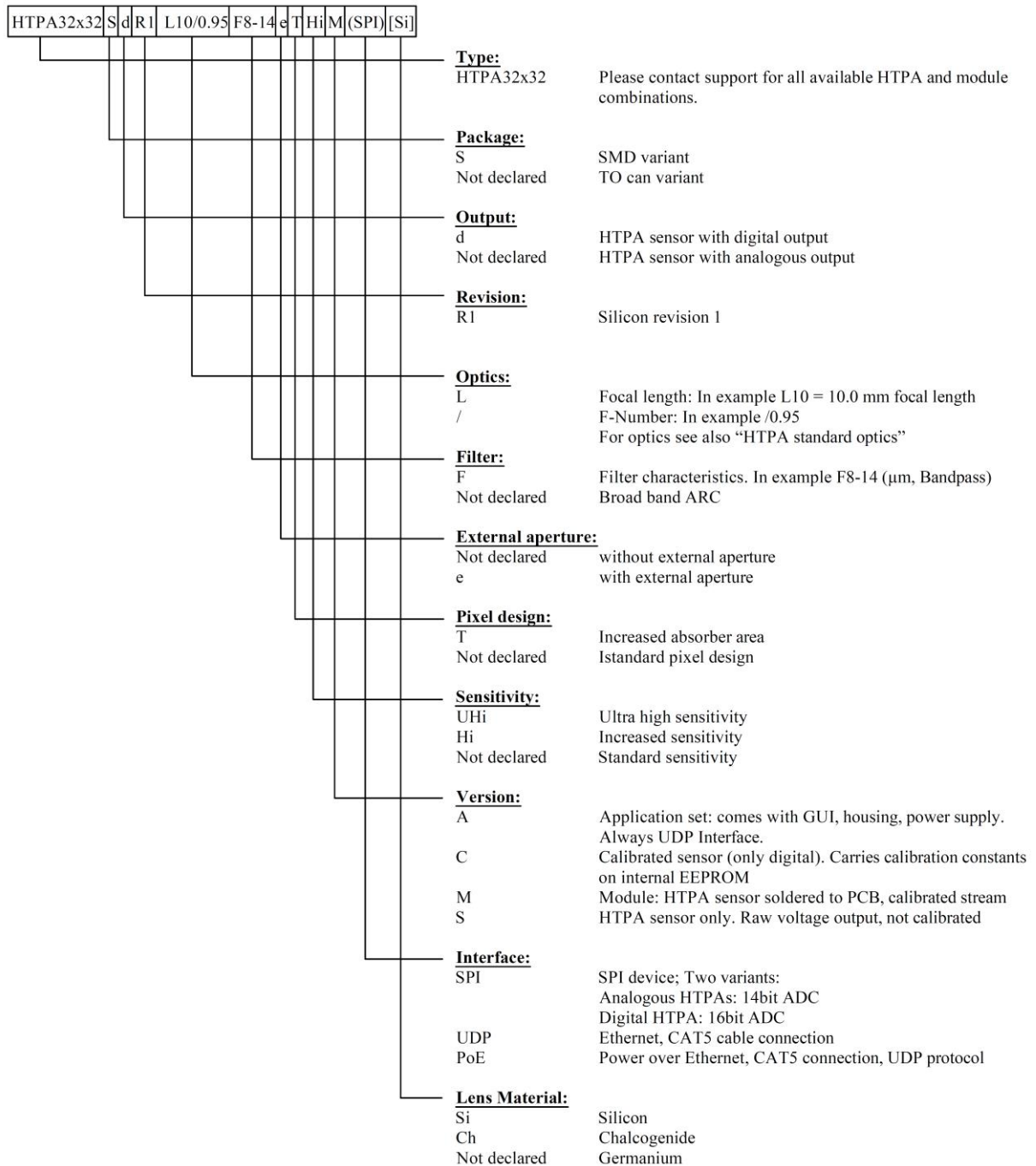

Figure 5: Exemplary order code

# HTPA120x84dL10/0.7UHiS

Thermopile Array with Lens Optics

Rev 7: 2023-11-14 Lupp / Nägler

Page 9 of 34

## 7 Application note

This Application Note is giving a short recommendation for the connection of the HTPA120x84d to achieve the best performance. Adding 100 nF and 47  $\mu$ F are improving the stability of the supply voltage.

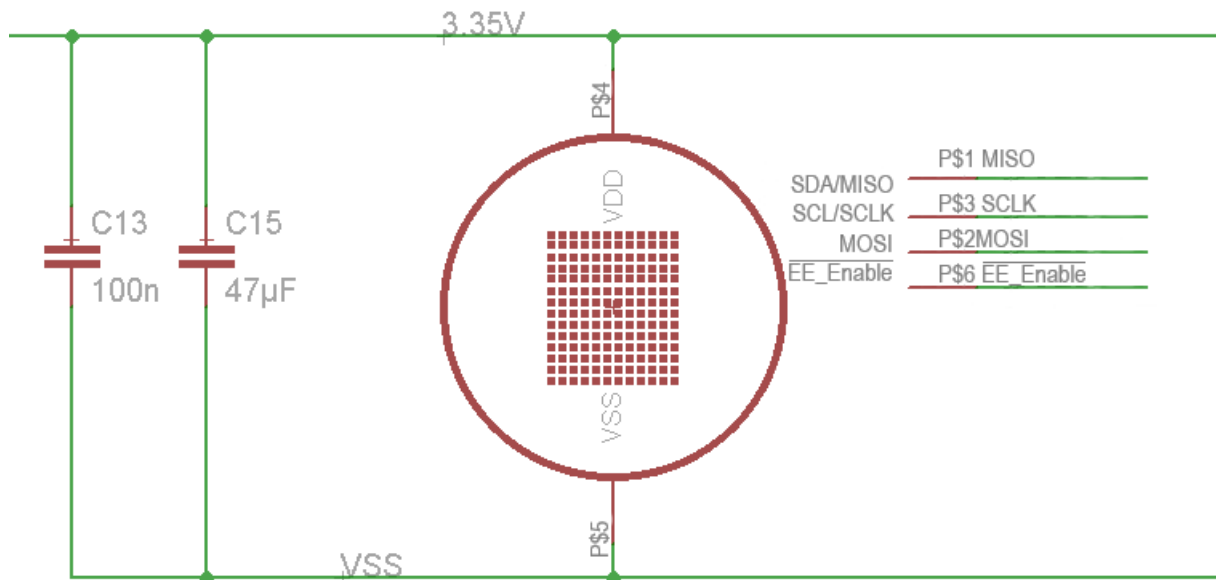

Figure 6: Recommended circuit for operation

The Sensor can be powered directly via 3.35 V if the supply voltage is stable enough, this has to be measured before and tested with the sensor. It is important to not insert any inductor or otherwise the noise will increase.

## 8 Serial Order of Frame

The sensor is divided into two parts (top and bottom half) which are again separated into 6 blocks. The readout order is shown below for the different blocks.

Block 0 (top)
Block 1 (top)
Block 2 (top)
Block 3 (top)
Block 4 (top)
Block 5 (top)
Block 5 (bottom)
Block 4 (bottom)
Block 3 (bottom)
Block 2 (bottom)
Block 1 (bottom)
Block 0 (bottom)

Figure 7: Division of blocks

Whenever a conversion is started the block x of the top and bottom half are measured at the same time. Each block consists of 840 Pixel that are sampled fully parallel. The readout order on the bottom half is mirrored compared to the top half so that the central lines are always read last.

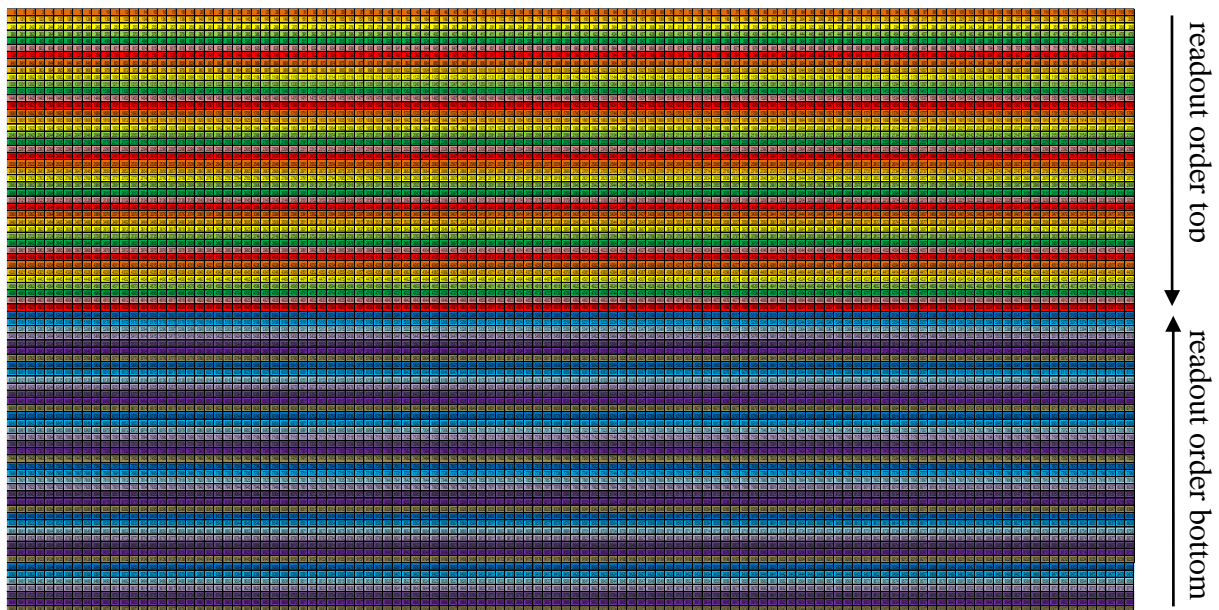

Figure 8: 120x84d readout order for active pixel

The electrical offsets are sampled according to the top and bottom half. The matching rows for the corresponding electrical offsets and active Pixel are marked with the same color. The conversion of the electrical offsets is started by setting the BLIND bit during the start command.

# HTPA120x84dL10/0.7UHiS

Thermopile Array with Lens Optics

Rev 7: 2023-11-14 Lupp / Nägler

Page 11 of 34

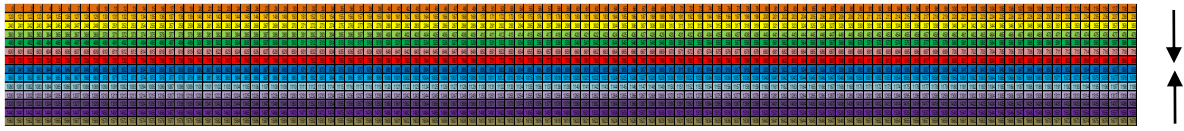

Figure 9: 120x84d readout order for electrical offset

# HTPA120x84dL10/0.7UHiS

Thermopile Array with Lens Optics

Rev 7: 2023-11-14 Lupp / Nägler

Page 12 of 34



## 9 Characteristics

### 9.1 Common Specifications

Technology	n-poly/p-poly Si
Typical Noise @9Hz	$150 \frac{nV}{\sqrt{Hz}}$
Thermal pixel time constant	<5 ms
Digital Interface	SPI
Analog Output	No
selectable Clock	6 to 16 MHz
EEPROM size	512 kBit
Pitch	60 $\mu$ m
Absorber size	52 $\mu$ m
Max. Framerate	50 Hz

(complete frame with maximum SPI and sensor clock speed and reduced ADC resolution)  
10080 sensitive elements

### 9.2 Optical characteristics

Focal length:	10.0 mm ("L" equals the focal length of the lens)
F-Number:	0.7
Field of view:	41 x 29 deg.
Lens coating:	LWP-Coating 7.7
	Cut On (Tr. 5%): 7.7 $\mu$ m $\pm$ 0.3 $\mu$ m
Accuracy:	$\pm$ 3 % or $\pm$ 3 K (whatever is larger) in the working ambient temperature range of 5 °C to 50 °C and object temperatures $\leq$ 300 °C within the radiometric radius.

## 10 Electric Specifications

Table 1: Absolute Maximum Ratings

Parameter	Symbol	Condition	MIN.	TYP.	MAX.	Unit
Supply Voltage	VDD		-0.3		3.6	V
Voltage at All inputs and outputs	VIO		-0.3		VDD+0.3	V
Storage Temperature	TSTG		-40		85	Deg. C

Table 2: Operating Conditions

Parameter	Symbol	Condition	MIN.	TYP.	MAX.	Unit
Supply Voltage	VDD		3.3	3.35	3.6	V
Supply Current (sensor running)	IDD		TBD	TBD	TBD	mA
Supply Current (sensor in idle state)	IDD		TBD	TBD	TBD	mA
Standby Current (sensor in sleep state)	ISBY		TBD	TBD	TBD	μA
Operation Temperature	TA		-20		85	Deg. C
ESD-Protection		Human body model	2.0			kV
		100pF + 1k50hm				

Table 3: Electrical Characteristics

Parameter	Symbol	Condition	MIN.	TYP.	MAX.	Unit
<b>Digital Input</b>						
Internal Clock frequency	FCLK		6	10	16	MHz
Internal I <sup>2</sup> C Pull up	RPU		1	100	100	kOhm

# HTPA120x84dL10/0.7UHiS

Thermopile Array with Lens Optics

Rev 7: 2023-11-14 Lupp / Nägler

Page 14 of 34



Bias current	IBIAS		1	3	13	μA
BPA current	IBPA		0.2	1.5	4.0	μA
Input voltage high	VIH		0.7xVDD			V
Input voltage low	VIL				0.3xVDD	V
PTAT						
Temperature range			TBD		TBD	Deg. C
PTAT gradient			352	377	400	K/V

Table 4: Preamplifier / ADC

Parameter	Symbol	Condition	MIN.	TYP.	MAX.	Unit
Chopper frequency	FCHP			40		kHz
Preamplifier Noise	NPA	at 20 kHz		72		nV/Hz <sup>1/2</sup>
Frame rate (Full Array)	FR1		6	9	15	Hz
Frame rate (Sixth part Array)	FR4		36	54	90	Hz
ADC pos. Reference	VREFP	REF_CAL 00		1.57		V
		REF_CAL 01		1.47		
		REF_CAL 10		1.37		
		REF_CAL 11		1.27		
ADC neg. Reference	VREFN	REF_CAL 00		0.78		V
		REF_CAL 01		0.88		
		REF_CAL 10		0.98		
		REF_CAL 11		1.08		
ADC resolution	ADCLS B	at 16 Bit	5.8		24.1	μV

## 11 SPI Timings HTPA120x84d

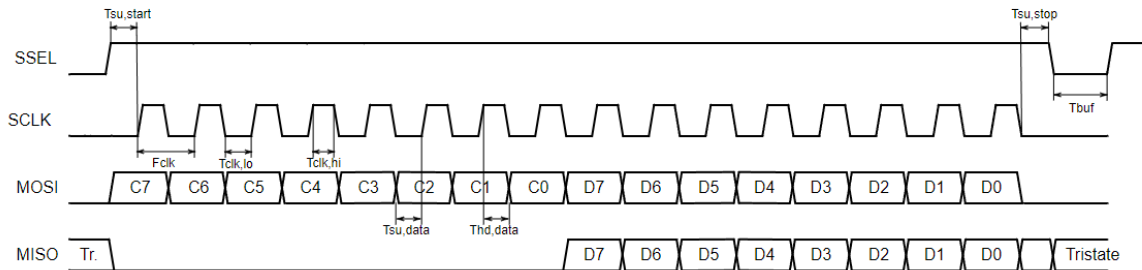

Figure 10: SPI Timings HTPA120x84d

Table 5: SPI Timings

Parameter	Symbol	MIN.	TYP.	MAX.	Unit
SPI clock frequency	FCLK		10		MHz
low pulse duration	T <sub>CLK,lo</sub>	30			ns
high pulse duration	T <sub>CLK,hi</sub>	40			ns
data set up time	T <sub>SU,data</sub>	30			ns
data hold time	T <sub>hd,data</sub>	10			ns
start setup time	T <sub>SU,start</sub>	50			ns
stop setup time	T <sub>SU,stop</sub>	50			ns
Time between STOP/ START	T <sub>buf</sub>	200			ns
Time startup (after Power-on Reset)	T <sub>startup</sub>			100	μs
Time wakeup (after sending WAKEUP)	T <sub>wakeup</sub>			80	μs

## 12 SPI Communication

The chip uses the 8-bit command for accessing configuration and sensor data.

The EE\_Enable pin is utilized to switch the communication between sensor and internal non-volatile memory. Due to the need to toggle the EE\_Enable pin the sensor with integrated EEPROM/FLASH requires a separate SPI interface. No other parts should use the same SPI lines in order to make sure that the parts can be selected correctly during communication.”

### 12.1 Write Command

In case of a write access to an internal register the command is followed by the data byte.

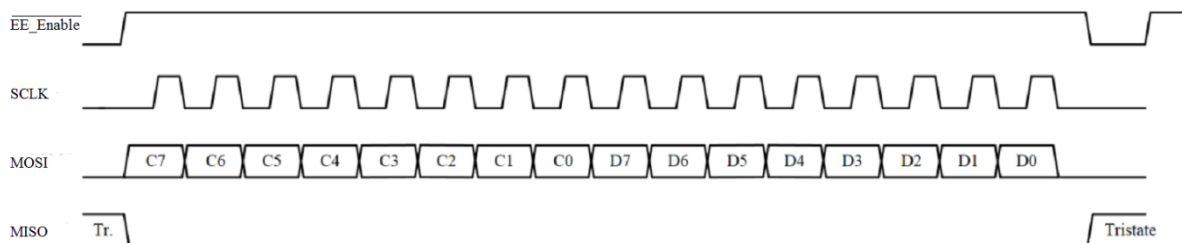

Figure 11: Write command

### 12.2 Read Command

To read data from the chip first the read command must be sent. The command initiates the read sequence and the first bit of read bytes will be set on MISO with falling edge of SCLK after last command bit. There can be as many byte reads as required.

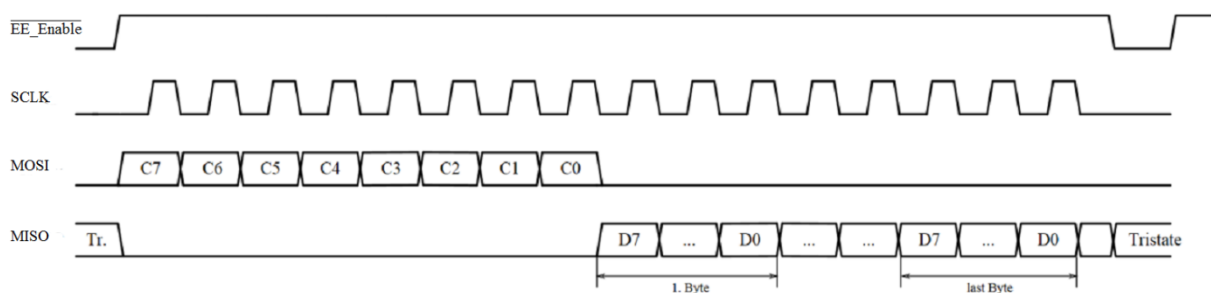

Figure 12: Read command

### 12.3 Sensor Commands

The sensor has several registers that can be written and read, they are listed below.

Table 6: Configuration register (write only)

Addr / CMD	0x01							
Status Reg	7	6	5	4	3	2	1	0
Name	RFU	BLOCK			START	VDD_MEAS	BLIND	WAKEUP
Default	0	0	0	0	0	0	0	0

The WAKEUP bit is used to switch on / off the chip and must be set prior all other operations. After the START bit is set the chip starts a conversion of the array or blind elements and enters the idle state (not sleep!) when finished. The BLOCK selects one of the four multiplexed array blocks.

If the BLIND bit is set the electrical offsets are sampled instead of the active pixel and the setting of the BLOCK is ignored.

If VDD\_MEAS bit is set the VDD voltage is measured instead of the PTAT value.

RFU means reserved for future use and can be subject to change.

Table 7: Status Register (read only)

Addr / CMD	0x02							
Status Reg	7	6	5	4	3	2	1	0
Name	RFU	BLOCK			RFU	VDD_MEAS	BLIND	EOC
Default	0	0	0	0	0	0	0	0

If the EOC flag is set a previous started conversion has been finished.

Table 8: Trim Register 1 (write only)

Addr / CMD	0x03							
Trim Reg 1	7	6	5	4	3	2	1	0
Name	RFU		REF_CAL			MBIT TRIM		

REF\_CAL: selectable amplification

MBIT\_TRIM:  $m = 4$  to  $12 \Rightarrow (m+4)$  bit as ADC resolution

Table 9: Trim Register 2 (write only)

Addr / CMD	0x04							
Trim Reg 2	7	6	5	4	3	2	1	0
Name	RFU				BIAS TRIM TOP			

BIAS\_TRIM\_TOP: 0 to 31  $\Rightarrow$  1 $\mu$ A to 13 $\mu$ A

This setting is used to adjust the bias current of the ADC. A faster clock frequency requires a higher bias current setting.

Table 10: Trim Register 3 (write only)

Addr / CMD	0x05							
Trim Reg 3	7	6	5	4	3	2	1	0
Name	RFU				BIAS TRIM BOT			

BIAS\_TRIM\_BOT: 0 to 31  $\Rightarrow$  1 $\mu$ A to 13 $\mu$ A

This setting is used to adjust the bias current of the ADC. A faster clock frequency requires a higher bias current setting.

Table 11: Trim Register 4 (write only)

Addr / CMD	0x06							
Trim Reg 4	7	6	5	4	3	2	1	0
Name	RFU				CLK TRIM			

CLK\_TRIM: 0 to 63  $\Rightarrow$  6MHz to 16MHz

NOTE: The measure time depends on the clock frequency settings. One sixth frame takes about:

$$t_{conv} \approx \frac{32 \cdot (2^{MBIT} + 100)}{F_{CLK}} \approx 14 \text{ ms @ } 10 \text{ MHz}$$

Table 12: Trim Register 5 (write only)

Addr / CMD	0x07							
Trim Reg 5	7	6	5	4	3	2	1	0
Name	RFU				BPA TRIM TOP			

BPA\_TRIM\_TOP: 0 to 31  $\Rightarrow$  0.2 $\mu$ A to 4.0 $\mu$ A

This setting is used to adjust the common mode current of the preamplifier.

Table 13: Trim Register 6 (write only)

Addr / CMD	0x08							
Trim Reg 6	7	6	5	4	3	2	1	0
Name	RFU				BPA TRIM BOT			

BPA\_TRIM\_BOT: 0 to 31  $\Rightarrow$  0.2 $\mu$ A to 4.0 $\mu$ A

This setting is used to adjust the common mode current of the preamplifier.

Table 14: Read Data 1 Command (Top Half of Array)

CMD	0x0A							
Read Data	7	6	5	4	3	2	1	0
1. Byte / 2. Byte	PTAT 1 MSB / LSB or Vdd 1 MSB / LSB							
3. Byte / 4. Byte	Pixel (0+BLOCK*840) MSB / LSB							
5. Byte / 6. Byte	Pixel (1+BLOCK*840) MSB / LSB							
...	...							
1681. Byte / 1682. Byte	Pixel (839+BLOCK*840) MSB / LSB							

Table 15: Read Data 2 Command (Bottom Half of Array)

CMD	0x0B							
Read Data	7	6	5	4	3	2	1	0
1. Byte / 2. Byte	PTAT 2 MSB / LSB or Vdd 2 MSB / LSB							
3. Byte / 4. Byte	Pixel (9960-BLOCK*840) MSB / LSB							
5. Byte / 6. Byte	Pixel (9961-BLOCK*840) MSB / LSB							
...	...							
241. Byte / 242. Byte	Pixel (10079-BLOCK*840) MSB / LSB							
243. Byte / 244. Byte	Pixel (9840-BLOCK*840) MSB / LSB							
245. Byte / 246. Byte	Pixel (9841-BLOCK*840) MSB / LSB							
...	...							
481. Byte / 482. Byte	Pixel (9959-BLOCK*840) MSB / LSB							
483. Byte / 484. Byte	Pixel (9720-BLOCK*840) MSB / LSB							
...	...							
1681. Byte / 1682. Byte	Pixel (9359-BLOCK*840) MSB / LSB							

The complete sensor data must be read at once. If the communication fails somewhere in between, all successive data will be corrupted. The readout can be stopped anywhere. A new initialized readout proceeds at this stopped byte, but the index is reset when a new conversion has been started.

If the VDD\_MEAS bit (Bit 2 in Config 0x01) is set then the Vdd is sampled instead of the PTAT.

If the bit for the electrical offsets (Bit 1 in Config 0x01) is set the electrical offsets are sampled and can be read similar to the active pixel:

Table 16: Read Data electrical offsets (Top Half of Array)

CMD	0x0A							
Read Data	7	6	5	4	3	2	1	0
1. Byte / 2. Byte	PTAT 1 MSB / LSB or Vdd 1 MSB / LSB							
3. Byte / 4. Byte	electrical offset (0) MSB / LSB							
5. Byte / 6. Byte	electrical offset (1) MSB / LSB							
...	...							
1681. Byte / 1682. Byte	electrical offset (839) MSB / LSB							

Table 17: Read Data electrical offsets (Bottom Half of Array)

### Read Data electrical offsets (Bottom Half of Array)

Addr / CMD	0x0B							
Read Data	7	6	5	4	3	2	1	0
1. Byte / 2. Byte	PTAT 2 MSB / LSB or VDD 2 MSB / LSB							
3. Byte / 4. Byte	electrical offset (1560) MSB / LSB							
5. Byte / 6. Byte	electrical offset (1561) MSB / LSB							
...	...							
241. Byte / 242. Byte	electrical offset (1679) MSB / LSB							
243. Byte / 244. Byte	electrical offset (1440) MSB / LSB							
...	...							
1681. Byte / 1682. Byte	electrical offset (959) MSB / LSB							

The complete sensor data must be read at once. If the communication fails somewhere in between, all successive data will be corrupted. The readout can be stopped anywhere. A new initialized readout proceeds at this stopped byte, but the index is reset when a new conversion has been started.

## 12.4 EEPROM communication

The built-in EEPROM (25AA512 from Microchip) consists of 32 blocks of 1K x 8-bit. The chip select of the EEPROM is set to 0. For further information, please see the corresponding datasheet directly from Microchip.

[www.microchip.com](http://www.microchip.com)

# HTPA120x84dL10/0.7UHiS

Thermopile Array with Lens Optics

Rev 7: 2023-11-14 Lupp / Nägler

Page 21 of 34



## 12.5 SPI Example Sequences – Init and Read Thermopile Array

CONFIG_REG	WAKEUP
0x01	0x01

TRIM_REG1	MBIT_TRIM
0x03	0x0C

TRIM_REG2	BIAS_TRIML
0x04	0x0C

TRIM_REG3	BIAS_TRIMR
0x05	0x0C

TRIM_REG4	CLK_TRIM
0x06	0x14

TRIM_REG5	BPA_TRIML
0x07	0x0C

TRIM_REG6	BPA_TRIMR
0x08	0x0C

---

CONFIG_REG	START   WAKEUP
0x01	0x09

STATUS_REG	STATUS
0x02	??

WAIT 30ms

STATUS_REG	STATUS
0x02	??

READ_DATA 1	PTAT1 MSB	PTAT1 LSB	P0,0 MSB	P0,0 LSB	...	Px,y MSB	Px,y LSB
0x0A	??	??	??	??	...	??	??

READ_DATA 2	PTAT2 MSB	PTAT2 LSB	P0,0 MSB	P0,0 LSB	...	Px,y MSB	Px,y LSB
0x0B	??	??	??	??	...	??	??

---

CONFIG_REG	SLEEP
0x01	0x00

### 13 Temperature calculation

The object and ambient temperature can be calculated from the sensor output and the stored calibration data. The table below is showing an overview of the EEPROM.

120x84d	0x00	0x01	0x02	0x03	0x04	0x05	0x06	0x07	0x08	0x09	0x0A	0x0B	0x0C	0x0D	0x0E	0x0F
0x0000	PixCmin (float)			PixCmax (float)			gradScale		TN as 16 bit unsigned			epsilon				
0x0010											MBIT(calib)	BIAS(calib)	CLK(calib)	BPA(calib)		
0x0020			Arraytype				VDDTH1	VDDTH2								
0x0030				PTAT-gradient (float)				PTAT-offset (float)			PTAT (Th1)		PTAT (Th2)			
0x0040														VddScGrad	VddScOff	
0x0050					GlobalOff	GlobalGain										
0x0060	MBIT(user)	BIAS(user)	CLK(user)	BPA(user)												
0x0070					DeviceID											NrOfDefPix
0x0080	DeadPixAdr as 16 bit unsigned values															
...																
0x00D0	DeadPixMask															
0x00E0																
0x00F0																
0x0100	free to use															
0x0110																
...																
0x20E0	VddCompGrad stored as 16 bit sigend values															
...																
0x2DF0																
0x2E00	VddCompOff stored as 16 bit sigend values															
...																
0x3B10																
0x3B20	ThGrad <sub>i</sub> stored as 8 bit signed values															
...																
0x6270																
0x6280	ThOffset <sub>i</sub> stored as 16 bit signed values															
...																
0xB130																
0xB140	P <sub>i</sub> stored as 16 bit unsigned values															
...																
0xFFFF																

Figure 13: EEPROM overview 120x84d

All values are stored as unsigned 8 bit values unless they are specified otherwise. The little endian format is used for larger values. Grey marked areas are used during calibration or for future use and are Heimann Sensor reserved.

MBIT(calib), BIAS(calib), CLK(calib), and BPA(calib) are the settings for the registers that have been used during calibration. We recommend the usage of calibration settings of MBIT (stored in 0x1A), BIAS (0x1B), CLK (0x1C) and BPA (0x1D).

MBIT(user), BIAS(user), CLK(user) and BPA(user) are free to be set by the user.

The temperature calculation is only valid if the same settings are used that have been set during calibration!

TN is the tablenumber and has to match the given tablenumber in the sample code.

GlobalOff is stored as an 8-bit signed value, GlobalGain and VddCalib are both stored as 16 bit unsigned.

VDDTH1 and VDDTH2 is the used supply voltage during calibration measured by the sensor itself and stored in Digits.

# HTPA120x84dL10/0.7UHiS

Thermopile Array with Lens Optics

Rev 7: 2023-11-14 Lupp / Nägler

Page 23 of 34



The corresponding order of  $ThGrad_{ij}$ ,  $ThOffset_{ij}$  and  $P_{ij}$  to the Pixel number is given by the following overview:

ThGrad <sub>0,0</sub> → Pixel 0	ThGrad <sub>0,1</sub> → Pixel 1	...	ThGrad <sub>0,119</sub> → Pixel 119
ThGrad <sub>1,0</sub> → Pixel 120	ThGrad <sub>1,1</sub> → Pixel 121	...	ThGrad <sub>1,119</sub> → Pixel 239
...			
ThGrad <sub>41,0</sub> → Pixel 3240	ThGrad <sub>41,1</sub> → Pixel 3241	...	ThGrad <sub>41,119</sub> → Pixel 3359
ThGrad <sub>42,0</sub> → Pixel 9960	ThGrad <sub>42,1</sub> → Pixel 9961	...	ThGrad <sub>42,119</sub> → Pixel 10079
ThGrad <sub>43,0</sub> → Pixel 9840	ThGrad <sub>43,1</sub> → Pixel 9841	...	ThGrad <sub>43,119</sub> → Pixel 9959
...			
ThGrad <sub>83,0</sub> → Pixel 3360	ThGrad <sub>83,1</sub> → Pixel 3361	...	ThGrad <sub>83,119</sub> → Pixel 3479

Figure 14: Readout order 120x84d

The order of  $VddCompGrad_{ij}$  and  $VddCompOff_{ij}$  is similar to the electrical Offsets and have to be used block by block.

VDDCompGrad <sub>0,0</sub> → Pixel 0	VDDCompGrad <sub>0,1</sub> → Pixel 1	...	VDDCompGrad <sub>0,119</sub> → Pixel 119	top half
VDDCompGrad <sub>1,0</sub> → Pixel 120	VDDCompGrad <sub>1,1</sub> → Pixel 121	...	VDDCompGrad <sub>1,119</sub> → Pixel 239	
...				
VDDCompGrad <sub>6,0</sub> → Pixel 720	VDDCompGrad <sub>6,1</sub> → Pixel 721	...	VDDCompGrad <sub>6,119</sub> → Pixel 839	
VDDCompGrad <sub>8,0</sub> → Pixel 840	VDDCompGrad <sub>8,1</sub> → Pixel 841	...	VDDCompGrad <sub>8,119</sub> → Pixel 959	
...				
VDDCompGrad <sub>6,0</sub> → Pixel 4920	VDDCompGrad <sub>6,1</sub> → Pixel 4921	...	VDDCompGrad <sub>6,119</sub> → Pixel 5039	
VDDCompGrad <sub>7,0</sub> → Pixel 9960	VDDCompGrad <sub>7,1</sub> → Pixel 9961	...	VDDCompGrad <sub>7,119</sub> → Pixel 10079	
VDDCompGrad <sub>8,0</sub> → Pixel 9840	VDDCompGrad <sub>8,1</sub> → Pixel 9841	...	VDDCompGrad <sub>8,119</sub> → Pixel 9959	
...				
VDDCompGrad <sub>13,0</sub> → Pixel 9240	VDDCompGrad <sub>13,1</sub> → Pixel 9241	...	VDDCompGrad <sub>13,119</sub> → Pixel 9359	bottom half
VDDCompGrad <sub>9,0</sub> → Pixel 9120	VDDCompGrad <sub>9,1</sub> → Pixel 9121	...	VDDCompGrad <sub>9,119</sub> → Pixel 9239	
...				
VDDCompGrad <sub>13,0</sub> → Pixel 5040	VDDCompGrad <sub>13,1</sub> → Pixel 5041	...	VDDCompGrad <sub>13,119</sub> → Pixel 5159	

Figure 15: Readout order of VDDCompGrad 120x84d

## 13.1 Ambient Temperature

The ambient temperature ( $T_a$ ) is calculated from the average measured PTAT value, the PTAT<sub>gradient</sub> and the PTAT<sub>offset</sub>. It is recommended to use a stack buffer for the PTAT values in order to get a more stable ambient temperature result.

$$T_a = PTAT_{av} \cdot PTAT_{gradient} + PTAT_{offset} \quad (\text{Value is given back in dK})$$

where:

$PTAT_{gradient}$  is the gradient of the PTAT stored in the EEPROM as a float value

$PTAT_{offset}$  is the offset of the PTAT stored in the EEPROM as a float value

$PTAT_{av} = \frac{\sum_{i=0}^{11} PTAT_{ij}}{12}$  is the average measured PTAT value

## 13.2 Thermal Offset

The thermal offset of the sensor needs to be subtracted for each pixel to compensate for any thermal drifts.

$$V_{ij\_Comp} = V_{ij} - \frac{ThGrad_{ij} \cdot PTAT_{av}}{2gradScale} - ThOffset_{ij}$$

where:

$ij$  represents the row (i) and column (j) of the pixel

$V_{ij\_Comp}$  is the thermal offset compensated voltage

$V_{ij}$  is the raw pixel data (digital), readout from the RAM

$ThGrad_{ij}$  is the thermal gradient, stored in the EEPROM from 0x3B20 to 0x6270

$ThOffset_{ij}$  is the thermal offset, stored in the EEPROM from 0x6280 to 0xB130

$gradScale$  is the scaling coefficient for the thermal gradient stored in the EEPROM

## 13.3 Electrical Offset

The electrical offset is used to compensate changes in the supply voltage. This compensation is only a subtraction so it can be done before or after the thermal offset compensation (here done afterwards). It is recommended to use an electrical offset stack in order to get a more stable electrical offset result and a more stable temperature result at the end. The electrical offsets should be sampled every 8th to 10th frame.

The compensation for the top half is done by using the following formula:

$$V_{ij\_Comp}^* = V_{ij\_Comp} - elOffset[(j + i \cdot 120)\%840]$$

and the bottom half analogue with this formula:

$$V_{ij\_Comp}^* = V_{ij\_Comp} - elOffset[(j + i \cdot 120)\%840 + 840]$$

where:

$ij$  represents the row (i) and column (j) of the pixel and electrical offset

$V_{ij\_Comp}^*$  is the thermal and electrical offset compensated voltage

$V_{ij\_Comp}$  is the thermal offset compensated voltage

$elOffset_{ij}$  is the electrical offset belonging to Pixel ij

$i\%840$  is the rest of the integer division of i by 840 (e.g.  $842\%840=2$ )

## 13.4 Vdd Compensation

A supply voltage compensation called VddComp is used to take care of supply voltage changes. In order to use this compensation the supply voltage of the sensor (Vdd) has to be measured by the sensor from time to time by setting the configuration register and the average of Vdd 1 and Vdd 2 is resulting in Vdd (similar like  $PTAT_{av}$ ). It is recommended to use a VDD stack buffer in order to get a more stable VDD value. The stack should be similar to the PTAT stack.

The compensation for the top half is done by using the following formula:

$$VDD_{av} = \frac{\sum_{i=0}^{11} VDD_i}{12}$$

$$V_{ijVDDComp} = V_{ijComp}^* - \left( \frac{VddCompGrad[(j + i \cdot 120)\%840] \cdot PTAT_{av}}{2VDDScGrad} + VddCompOff[(j + i \cdot 120)\%840] \right) / 2VDDScOff$$

# HTPA120x84dL10/0.7UHiS

Thermopile Array with Lens Optics

Rev 7: 2023-11-14 Lupp / Nögler

Page 26 of 34



$$\cdot \left( VDD_{av} - VDD_{TH1} - \left( \frac{VDD_{TH2} - VDD_{TH1}}{PTAT_{TH2} - PTAT_{TH1}} \right) \cdot (PTAT_{av} - PTAT_{TH1}) \right)$$

and the bottom half analogue with this formula:

$$V_{ij\_VDDComp} = V_{ij\_Comp}^*$$

$$\frac{\left( \frac{VddCompGrad[(j + i \cdot 120)\%840 + 840] \cdot PTAT_{av} + VddCompOff[(j + i \cdot 120)\%840 + 840]}{2^{VDDScGrad}} \right)}{2^{VDDScOff}} \cdot \left( VDD_{av} - VDD_{TH1} - \left( \frac{VDD_{TH2} - VDD_{TH1}}{PTAT_{TH2} - PTAT_{TH1}} \right) \cdot (PTAT_{av} - PTAT_{TH1}) \right)$$

where:

$ij$	represents the row (i) and column (j) of the pixel
$V_{ij\_VDDComp}$	is the Vdd compensated voltage
$V_{ij\_Comp}^*$	is the thermal and electrical offset compensated voltage
$VddComGrad[ij]$	is the VddComp gradient belonging to Pixel ij
$VddComOff[ij]$	is the VddComp offset belonging to Pixel ij
$i\%840$	is the rest of the integer division of i by 840 (e.g. $842\%840=2$ )
$VDD_{av}$	is the average measured supply voltage of the sensor in Digits
$VddScGrad$	is a scaling coefficient and stored in the EEPROM 0x4E
$VddScOff$	is a scaling coefficient and stored in the EEPROM 0x4F
$VDD_{TH1}$	is the supply voltage during calibration 1 stored in the EEPROM 0x26, 0x27
$VDD_{TH2}$	is the supply voltage during calibration 2 stored in the EEPROM 0x28, 0x29
$PTAT_{TH1}$	is the PTAT value of calibration 1 stored in the EEPROM 0x3C, 0x3D
$PTAT_{TH2}$	is the PTAT value of calibration 2 stored in the EEPROM 0x3E, 0x3F

## 13.5 Object Temperature

The calculation of the object temperature is done by using a look-up table and doing a bi-linear interpolation, the matching table is given by the tablenumber (TN). The table is supplied in a separate file named "Table.c". If you do not have the file, please ask Heimann Sensor for support.

The sensitivity coefficients ( $PixC_{ij}$ ) are calculated in the following way:

$$PixC_{ij} = \left( \frac{P_{ij} \cdot (PixC_{max} - PixC_{min})}{65535} + PixC_{min} \right) \cdot \frac{\epsilon}{100} \cdot \frac{GlobalGain}{10000}$$

where:

$PixC_{ij}$  is the sensitivity coefficient for each pixel

$P_{ij}$  is the stored sensitivity coefficient scaled to 16 bit

$PixC_{min}$  is the minimum sensitivity coefficient, used for scaling

$PixC_{max}$  is the maximum sensitivity coefficient, used for scaling

$\epsilon$  is the emissivity factor

$GlobalGain$  is a factor for fine tuning of the sensitivity for all Pixel

Leading to a compensation of the pixel voltage

$$V_{if\_PixC} = \frac{V_{ij\_VDDComp} \cdot PCSCALEVAL}{PixC_{ij}}$$

where:

$V_{if\_PixC}$  is the sensitivity compensated IR voltage

$PCSCALEVAL$  is a defined scaling coefficient, typically set to  $1 \cdot 10^8$

## 14 Example calculation

Example values:

$$PTAT_{av} = \frac{\sum_{i=0}^{11} PTAT_i}{12} = 38152 \text{Digits}$$

$$PTAT_{gradient} = 0.0211 \text{ dK/Digit}$$

$$PTAT_{offset} = 2195.0 \text{ dK}$$

$$V_{00} = 34435 \text{ Digits}$$

$$elOffset[0] = 34240$$

$$gradScale = 17$$

$$THGrad_{00} = 87 \rightarrow \text{signcheck } 87$$

$$THOffset_{00} = 65506 \rightarrow \text{signcheck } - 30$$

$$VDD_{av} = 35000$$

$$VDD_{TH1} = 33942$$

$$VDD_{TH2} = 36942$$

$$PTAT_{TH1} = 30000$$

$$PTAT_{TH2} = 42000$$

$$VddCompGrad[0] = 10356 \rightarrow \text{signcheck } 10356$$

$$VddCompOff[0] = 51390 \rightarrow \text{signcheck } - 14146$$

$$VddScGrad = 16$$

$$VddScOff = 23$$

$$PixC_{00} = 1.087 \cdot 10^8$$

$$PCSCALEVAL = 1 \cdot 10^8$$

Calculation of ambient temperature:

$$Ta = PTAT_{av} \cdot PTAT_{gradient} + PTAT_{offset} = 38152 \cdot 0.0211 + 2195.0 \text{ dK} = 3000 \text{ dK}$$

Compensation of thermal offset:

# HTPA120x84dL10/0.7UHiS

Thermopile Array with Lens Optics

Rev 7: 2023-11-14 Lupp / Nögler

Page 29 of 34



$$V_{00\_Comp} = V_{00} - \frac{ThGrad_{00} \cdot PTAT_{av}}{2^{gradScale}} - ThOffset_{00} = 34435 - \frac{87 \cdot 38152}{2^{17}} - (-30)$$

$$= 34439$$

Compensation of electrical offset:

$$V_{00\_Comp}^* = V_{00\_Comp} - elOffset[0] = 34439 - 34240 = 199$$

Compensation of supply voltage:

$$V_{ij\_VDDComp} = V_{ij\_Comp}^* - \frac{\left( \frac{VddCompGrad[0] \cdot PTAT_{av}}{2^{VddScGrad}} + VDDCompOff[0] \right)}{2^{VddScGrad}}$$

$$\cdot \left( VDD_{av} - VDD_{Th1} - \left( \frac{VDD_{TH2} - VDD_{TH1}}{PTAT_{TH2} - PTAT_{TH1}} \right) \cdot (PTAT_{av} - PTAT_{TH1}) \right)$$

$$= 199 - \frac{\left( \frac{10356 \cdot 38152}{2^{16}} - 14146 \right) \cdot (35000 - 33942 - 2038)}{2^{23}} = 199 - (1) = 198$$

Table 18: Example look-up table

TA[dK]/dig	2882	3032	3182	3332
-64	1494	2128	2491	2775
-32	2466	2692	2898	3091
0	2882	3032	3182	3332
32	3170	3285	3406	3530
64	3396	3491	3592	3699
96	3584	3665	3754	3848
128	3746	3818	3897	3981
160	3890	3954	4025	4102
192	4019	4078	4143	4214
224	4137	4191	4251	4317
256	4246	4296	4351	4413
288	4347	4393	4445	4503
320	4441	4485	4534	4588

$$V_{00\_PixC} = \frac{198 \cdot 1 \cdot 10^8}{1.087 \cdot 10^8} = 182$$

Ta was calculated before to 3000 dK.

The matching region in the look-up table is already marked yellow, the bi-linear interpolation is leading to an object temperature of  $4026 \text{ dK} = 129.4 \text{ °C}$ .

A global Offset (GlobalOff) is used for fine tuning of the measured object temperature and has to be added to the object temperature. This value is stored in the EEPROM.

## 14.1 Pixel Masking

A maximum of 48 defect Pixels is allowed on the complete array; this means that at least 99.5 % of the Pixels are working correctly. The amount of defect Pixels is given in the EEPROM at address  $0x007F$  and is named *NrOfDefPix*. *DeadPixAdr* is the address of the defect Pixels and *DeadPixMask* determines the neighbours that should be used for masking the pixel. A simple averaging of all selected nearest neighbours is done to overwrite the temperature value of these Pixel. Only the amount of pixels “*NrOfDefPix*” is stored in *DeadPixAdr*. These values are stored as 16 bit unsigned values. For example: If only one pixel has to be masked, then the other values of *DeadPixAdr* are set to 0.

The order of the top and bottom half is the same as the readout order. The neighbours to use is given in a binary format and the order is shown in the overview below in decimal and binary values for the top and bottom half.

$$\text{adaptedAdr}[i] = 10080 + 5040 - \text{DeadPixAdr}[i] + k[i] \cdot 2 - 120$$

where:

*adaptedAdr*[*i*] is the adapted dead pixel address

*k*[*i*] is the column of the corresponding pixel (for pixel number 9959 this would be 119)

$$\text{adaptedAdr}[i] = 10080 + 5040 - 9959 + 119 \cdot 2 - 120 = 5279$$

# HTPA120x84dL10/0.7UHiS

Thermopile Array with Lens Optics

Rev 7: 2023-11-14 Lupp / Nägler

Page 31 of 34



top half

128	1	2
64	DeadPix	4
32	16	8

0b1000 0000	0b0000 0001	0b0000 0010
0b0100 0000	DeadPix	0b0000 0100
0b0010 0000	0b0001 0000	0b0000 1000

bottom half

32	16	8
64	DeadPix	4
128	1	2

0b0010 0000	0b0001 0000	0b0000 1000
0b0100 0000	DeadPix	0b0000 0100
0b1000 0000	0b0000 0001	0b0000 0010

Example values for the masking:

$NrOfDefPix = 0x03$

$DeadPixAdr[0] = 0x002D \rightarrow Pixel\ 45$

$DeadPixAdr[1] = 0x031F \rightarrow Pixel\ 799$

$DeadPixAdr[2] = 0x1429 \rightarrow Pixel\ 5161(read - out\ pixel)actual\ pixel\ number\ is\ 9841$

$DeadPixMask[0] = 0x7C \rightarrow 0b01111100(top)$

$DeadPixMask[1] = 0x8F \rightarrow 0b10001111(top)$

$DeadPixMask[2] = 0xFE \rightarrow 0b11111110(bot)$

According to the sample values 3 Pixels are defect and need to be interpolated. 2 Pixels are on the top and 1 Pixel on the bottom half. Assuming that the neighbouring Pixels are having the temperature data stated below and the green marked cells are used for averaging (according to DeadPixMask) then the interpolated temperature will be the following:

# HTPA120x84dL10/0.7UHiS

Thermopile Array with Lens Optics

Rev 7: 2023-11-14 Lupp / Nägler

Page 32 of 34



All values are given in dK

3007	Pixel 45	3008
3008	3011	3009

Pixel 44	Pixel 45	Pixel 46
Pixel 163	Pixel 164	Pixel 165

3010	3012	3005
3007	Pixel 799	3008
3008	3011	3009

Pixel 678	Pixel 679	Pixel 680
Pixel 798	Pixel 799	Pixel 800
Pixel 918	Pixel 919	Pixel 920

3010	3012	3005
3007	Pixel 9841	3008
3008	3011	3009

Pixel 9720	Pixel 9721	Pixel 9722
Pixel 9840	Pixel 9841	Pixel 9842
Pixel 9960	Pixel 9961	Pixel 9962

If a pixel is masked, the adjacent neighbours must have not more than 4 dead pixels in serial order, if you check them clockwise (or the other way around):

OK		
0	1	0
0	0	1
1	0	0

OK		
0	1	0
0	0	1
0	0	1

NOK		
0	1	1
0	0	1
0	0	0

# HTPA120x84dL10/0.7UHIS

Thermopile Array with Lens Optics

Rev 7: 2023-11-14 Lupp / Nägler

Page 33 of 34



## 14.2 Look-up Table

The matching look-up table has to be taken from the Table.c file. Here is just shown an exemplary data for one optics.

dig \ Tai[dK]	2782	2882	2982	3082	3182	3282	3382
-256				1159	1804	2115	2343
-192				2211	2407	2576	2727
-128				2635	2742	2872	2995
-64				2873	2986	3097	3206
0	2782	2882	2982	3082	3182	3282	3382
64	2993	3078	3166	3256	3347	3440	3534
128	3167	3243	3322	3405	3491	3579	3669
192	3316	3385	3459	3537	3619	3703	3790
256	3448	3512	3582	3656	3734	3816	3901
320	3565	3626	3693	3764	3840	3920	4003
384	3673	3731	3794	3864	3938	4016	4097
448	3771	3827	3889	3956	4029	4105	4186
512	3863	3916	3977	4043	4114	4189	4269
576	3948	4000	4059	4124	4194	4269	4348
640	4028	4079	4137	4200	4270	4344	4423
704	4104	4154	4210	4273	4342	4415	4494
768	4176	4224	4280	4342	4410	4484	4561
832	4247	4293	4348	4408	4476	4549	4626
896	4308	4356	4410	4471	4538	4611	4689
960	4371	4417	4471	4532	4599	4671	4748
1024	4431	4476	4530	4590	4657	4729	4806
1088	4488	4533	4586	4646	4713	4785	4862
1152	4543	4588	4641	4700	4767	4839	4916
1216	4597	4641	4693	4753	4819	4891	4968
1280	4648	4692	4744	4803	4869	4941	5018
1344	4698	4742	4793	4852	4918	4990	5068
1408	4746	4790	4841	4900	4966	5038	5115
1472	4793	4836	4888	4946	5012	5083	5162
1536	4839	4881	4933	4991	5057	5129	5207
1600	4883	4926	4977	5035	5101	5173	5251
1664	4926	4968	5019	5078	5144	5216	5294
1728	4968	5010	5061	5120	5185	5258	5336
1792	5009	5051	5102	5161	5226	5299	5377
1856	5049	5091	5142	5200	5266	5338	5417
1920	5088	5130	5180	5239	5305	5377	5456
1984	5126	5168	5218	5277	5343	5416	5494
2048	5164	5205	5256	5314	5380	5453	5532
2112	5203	5243	5293	5351	5417	5490	5569
2176	5236	5277	5328	5386	5453	5526	5605
2240	5271	5312	5363	5421	5488	5561	5640
2304	5305	5347	5397	5456	5522	5595	5675
2368	5338	5380	5431	5490	5556	5629	5709
2432	5372	5413	5464	5523	5589	5663	5742
2496	5405	5446	5496	5555	5622	5695	5775
2560	5437	5478	5528	5587	5654	5728	5808
2624	5468	5509	5559	5619	5685	5759	5840
2688	5498	5539	5589	5649	5716	5790	5871
2752	5529	5570	5621	5680	5747	5821	5902
2816	5559	5600	5651	5710	5777	5851	5932
2880	5588	5629	5680	5739	5806	5881	5962
2944	5617	5658	5709	5768	5836	5910	5992
3008	5646	5687	5737	5797	5864	5939	6021
3072	5674	5715	5765	5825	5893	5968	6049
3136	5701	5742	5793	5853	5920	5996	6078
3200	5729	5770	5820	5880	5948	6023	6105
3264	5756	5797	5847	5907	5975	6051	6133
3328	5783	5824	5874	5934	6002	6078	6160
3392	5808	5849	5900	5960	6028	6104	6187
3456	5834	5875	5926	5986	6054	6130	6213
3520	5859	5900	5951	6011	6080	6156	6239
3584	5885	5926	5977	6037	6105	6182	6265
3648	5910	5951	6002	6062	6131	6207	6290
3712	5934	5975	6026	6086	6155	6232	6315
3776	5958	5999	6050	6111	6180	6257	6340
3840	5982	6023	6074	6135	6204	6281	6365
3904	6006	6047	6098	6159	6228	6305	6389
3968	6029	6070	6121	6182	6251	6328	6413
4032	6052	6093	6145	6205	6275	6352	6437
4096	6075	6116	6167	6228	6298	6376	6460
4160	6097	6139	6190	6251	6321	6399	6484
4224	6120	6161	6212	6273	6343	6421	6507
4288	6142	6183	6234	6295	6365	6444	6529
4352	6164	6205	6257	6318	6388	6466	6552
4416	6185	6227	6278	6340	6410	6488	6574
4480	6207	6248	6300	6361	6432	6510	6596
4544	6228	6269	6321	6383	6453	6532	6618
4608	6249	6290	6342	6404	6475	6553	6639
4672	6269	6311	6363	6425	6496	6575	6661
4736	6290	6332	6384	6446	6516	6596	6682
4800	6310	6352	6404	6466	6537	6616	6703
4864	6330	6372	6424	6486	6558	6637	6724
4928	6350	6392	6444	6507	6578	6657	6744
4992	6370	6412	6464	6527	6598	6678	6765
5056	6390	6431	6484	6546	6618	6698	6785
5120	6409	6451	6503	6566	6638	6718	6805
5184	6429	6471	6523	6585	6657	6737	6825
5248	6447	6489	6542	6605	6677	6757	6845
5312	6466	6508	6561	6624	6696	6776	6864
5376	6485	6527	6580	6643	6715	6795	6884
5440	6504	6546	6599	6661	6734	6815	6903
5504	6522	6564	6617	6680	6752	6833	6922
5568	6540	6582	6635	6699	6771	6852	6941
5632	6558	6600	6654	6717	6789	6871	6960
5696	6576	6618	6672	6735	6808	6889	6978
5760	6594	6636	6690	6753	6826	6907	6997
5824	6612	6654	6707	6771	6844	6926	7015
5888	6629	6672	6725	6789	6862	6944	7033
5952	6647	6689	6742	6806	6879	6961	7051
6016	6664	6706	6760	6824	6897	6979	7069
6080	6681	6723	6777	6841	6914	6997	7087
6144	6698	6741	6794	6858	6932	7014	7104
6208	6715	6757	6811	6875	6949	7031	7122
6272	6732	6774	6828	6892	6966	7049	7139
6336	6748	6791	6845	6909	6983	7066	7156
6400	6765	6807	6861	6925	7000	7083	7174
6464	6781	6824	6878	6942	7016	7100	7191
6528	6797	6840	6894	6959	7033	7116	7207
6592	6813	6856	6910	6975	7050	7133	7224
6656	6830	6872	6927	6991	7066	7149	7241
6720	6846	6889	6943	7007	7082	7165	7257
6784	6861	6904	6958	7023	7098	7182	7274
6848	6877	6920	6974	7039	7114	7199	7291
6912	6892	6935	6989	7054	7129	7214	7306
6976	6907	6950	7004	7069	7144	7229	7321
7040	6922	6965	7019	7084	7159	7244	7336
7104	6937	6980	7034	7099	7174	7259	7351
7168	6951	6994	7048	7113	7188	7273	7365
7232	6965	7008	7062	7127	7202	7287	7379
7296	6979	7022	7076	7141	7216	7301	7393
7360	6993	7036	7090	7155	7230	7315	7407
7424	7007	7050	7104	7169	7244	7329	7421
7488	7021	7064	7118	7183	7258	7343	7435
7552	7035	7078	7132	7197	7272	7357	7449
7616	7049	7092	7146	7211	7286	7371	7463
7680	7063	7106	7160	7225	7300	7385	7477
7744	7077	7120	7174	7239	7314	7399	7491
7808	7091	7134	7188	7253	7328	7413	7505
7872	7105	7148	7202	7267	7342	7427	7519
7936	7119	7162	7216	7281	7356	7441	7533
8000	7133	7176	7230	7295	7370	7455	7547
8064	7147	7190	7244	7309	7384	7469	7561
8128	7161	7204	7258	7323	7398	7483	7575
8192	7175	7218	7272	7337	7412	7497	7589
8256	7189	7232	7286	7351	7426	7511	7603
8320	7203	7246	7300	7365	7440	7525	7617
8384	7217	7260	7314	7379	7454	7539	7631
8448	7231	7274	7328	7393	7468	7553	7645
8512	7245	7288	7342	7407			

# HTPA120x84dL10/0.7UHiS

Thermopile Array with Lens Optics

Rev 7: 2023-11-14 Lupp / Nägler

Page 34 of 34



## 15 Outer Dimensions

